

The Model EDB-640 offers a fully integrated CNC operation with superior accuracy and repeatability. The features of this DrillMate allow interactive programming with Real-time Path Display for reliability and program management.

- ✓ World's Fastest ATC (0.25 ~ 3.0mm)
- ✓ Ridged X & Y Axis Bridge Construction
- ✓ Design Allows for Heavy Work Piece
- ✓ Auto Electrode Wear Compensation
- ✓ Touch Screen (15" Monitor)
- ✓ Real-Time Tool Path Display
- ✓ Job Program Management
- ✓ Variable Spindle Speed
- ✓ Program Pattern Function
- ✓ Upper / Lower Die Guide
- ✓ Automatic Mid-Guide
- ✓ Dry Run Simulation
- ✓ Blind Hole Drilling
- ✓ MS 10 Windows
- ✓ Closed Loop DI Filtration
- ✓ 2000 PSI Filtration Pump (opt)
- ✓ A & B Rotary Table



Machine Specifications **Model EDB-640**

Max. Work Piece Size	39" x 27" x 17"
Max. Work Piece Weight	881 Lbs.
Table Travels (X - Y)	23.6" x 15.6"
Min. Z Axis Travel to Table	2.500"
W Axis Stroke	12"
Usable Electrode Diameter	0.1mm ~ 3.00 mm
Useable Electrode Length	11"

Power Supply

Max. Power Input	4 KVA
Input Power Supply (Volts) 3 Phase	208/220/240/480V 60Hz
Max. Machining Current	40 Amp

Dielectric Fluid Unit

Dielectric Fluid	Water / EDM Oil
Fluid Capacity	100 / 300 Liters
Deionize System	Standard

CNC Control

Input System	USB / MDI
Display	15" LCD Touch Screen
Position Command System	Incremental / Absolute
Min. Input Increment	0.001 mm
Operating System	Microsoft 10 Windows

Standard Features

Automatic Electrode Changer

Installation Dimensions

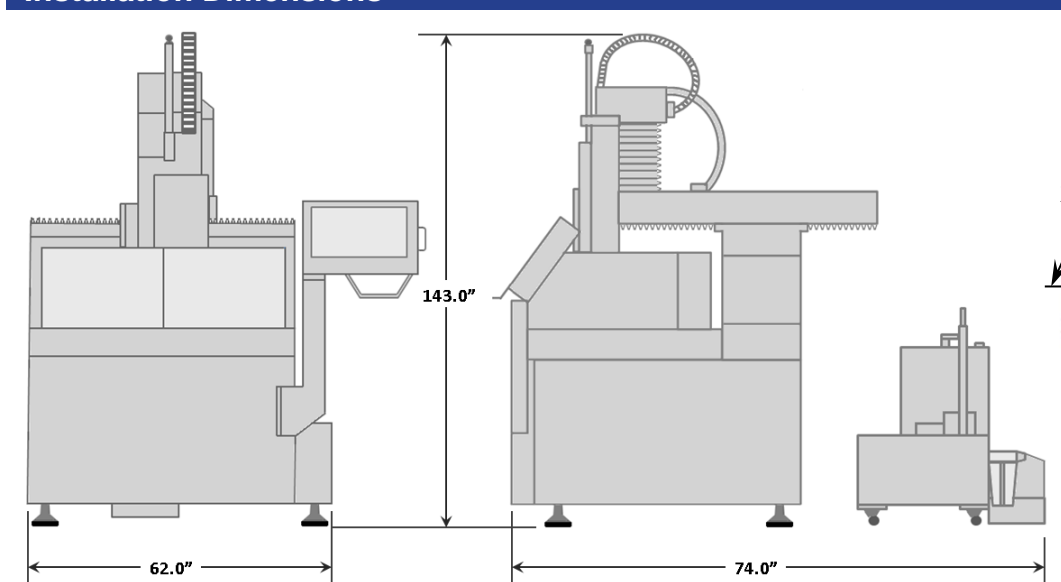

Automatic Electrode Changer



Assist Guide



Granite Work Table with T-Slots

